

GARY SHEET SLITTERS

Models 3350 & 3353

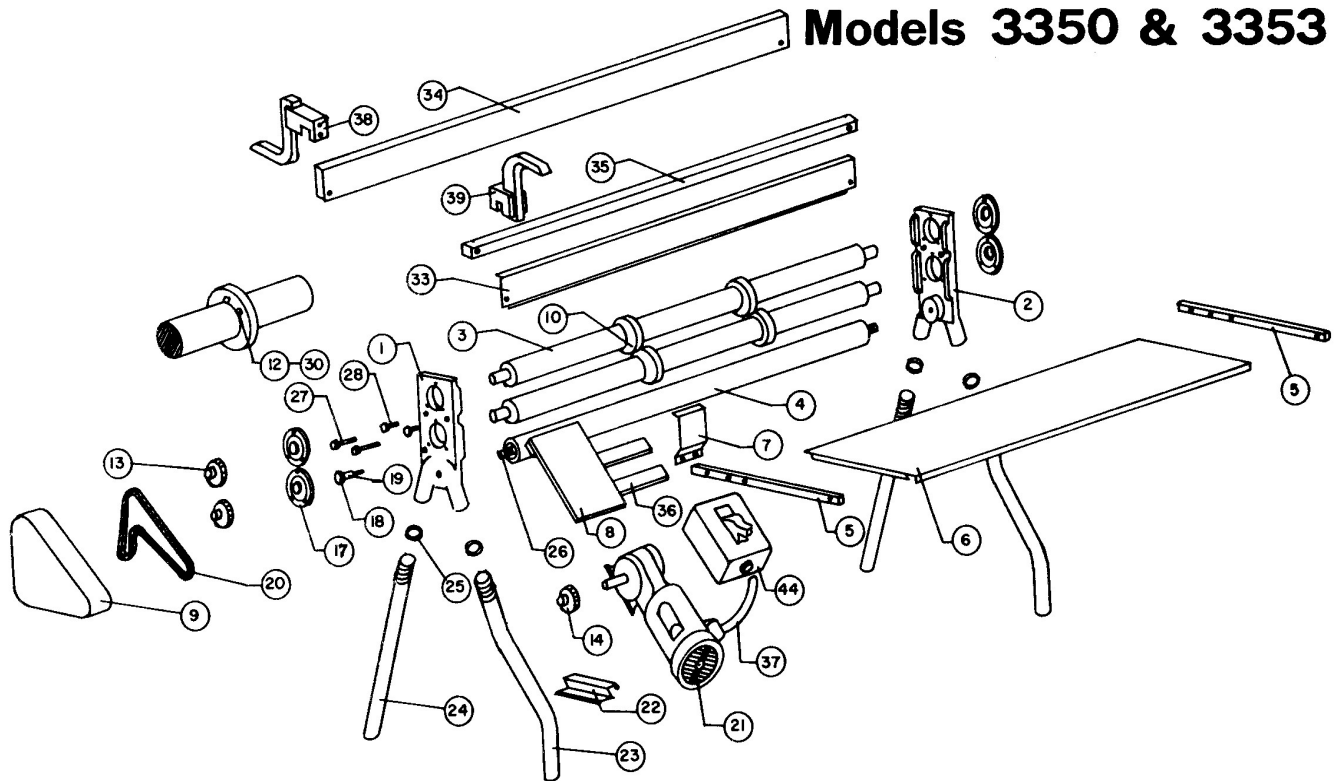

Part No.	Key No.	Description	Part No.	Key No.	Description
100014	1	Al-mag End Housing	100011	22	Sheetmetal Sheet Guide
100014	2	Al-mag End Housing	100020	23	Front Leg
100021	3	Knife Arbor- 3"OD x 57"	100019	24	Rear Leg
100016	4	Torsion Tube	285085	25	1-1/4" Drive Nut
100022	5	Cold Roll Gauge	100015	26	Draw Bolt 5/8"-11NC x 6'
100025	6	Table Assembly	275015	27	5/16" 18-N.C. Pull bolts
100024	7	Table Support	100421	28	Gauge Adjusting Bolt x 1.5"
101593	8	3350 & 3353 Motorbase	285018	30	3/8-24 x 1/2" Half Dog Point Set Screw
101596	9	3350 & 3353 Chain Guard	100033	33	Finger Guard
200027	10	3" x 5" x 3/4" STD Alloy Knives	100031	34	Front Stripper Bar
200028	10a	3" x 5" x 3/4" D2 (HCHC) Knives - Optional	100032	35	Rear Stripper Bar
285022	12	234 Gib Key	185015	38	Upper Stripper Finger Assembly
200017	13	4020 x 1- 7/16" Arbor Sprocket	185016	39	Lower Stripper Finger Assembly
200018	14a	4020 x 1" Motor Sprocket -STD.(60 fpm)	203100	44	3350/3351 C-H Starter
200005	14b	4015 x 1" Motor Sprocket (40 fpm)	203101	44a	8 Amp Heater (220 Volts)
200016	17a	Bearing Flange	203102	44b	14 Amp Heater (110 Volts)
200015	17b	1- 7/16" Arbor Bearing	100029	N.S.	Rear Stripper Bar Spacer
200003	18	1/2" ID Chain Idler Bearing	100030	N.S.	Front Stripper Bar Spacer
285026	19	Idler Bearing Bolt	200008	N.S.	Electric Cord w/Plug
285048	20	No. 40 Chain	200011	N.S.	3/16" T-Handle Allen Wrench
201255	21	3/4HP Rt-angle Gearmotor 45-rpm			

GARY SHEET SLITTERS

Model 3351

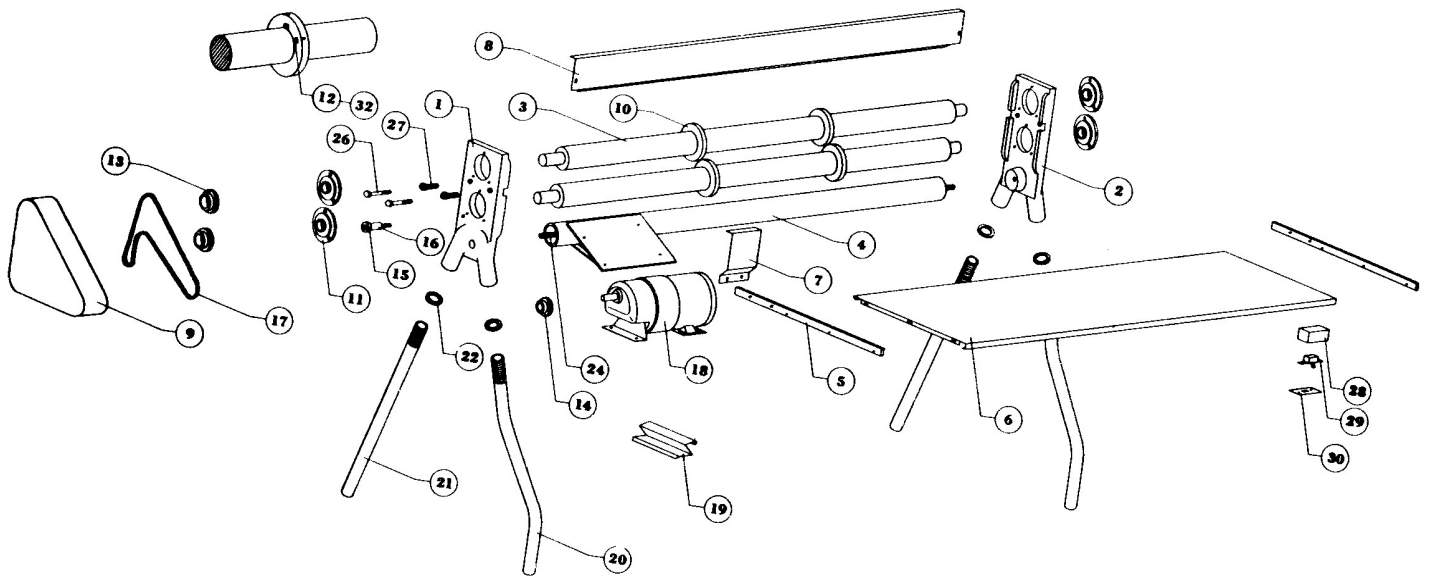

Part No.	Key No.	Description	Part No.	Key No.	Description
100014	1	Al-mag End Housing	200003	15	1/2" ID Chain Idler Bearing
100014	2	Al-mag End Housing	285026	16	Idler Bearing Bolt
100021	3	Knife Arbor- 3"OD x 57"	285048	17	No. 40 Chain
100016	4	Torsion Tube	200031	18	1/3HP Rt-angle Gearmotor 45-rpm
100022	5	Cold Roll Gauge	100011	19	Sheetmetal Sheet Guide
100025	6	Table Assembly	100020	20	Front Leg
100024	7	Table Support	100019	21	Rear Leg
100023	8	Finger Guard	285085	22	1-1/4" Drive Nut
100026	9	3351 Chain Guard	100015	24	Draw Bolt 5/8"-11NC x 6'
200027	10	3" x 5" x 3/4" STD Alloy Knives	275015	26	5/16" 18-N.C. Pull bolts
200028	10a	3" x 5" x 3/4" D2 (HCHC) Knives - Optional	100421	27	Gauge Adjusting Bolt x 1.5"
200015	11	1- 7/16" Arbor Bearing	203100	28	3350/3351 C-H Starter
200016	11a	Bearing Flange	203101	29	8 Amp Heater (110 Volts)
285022	12	234 Gib Key	200008	N.S.	Electric Cord w/Plug
200017	13	4020 x 1- 7/16" Arbor Sprocket	200011	N.S.	3/16" T-Handle Allen Wrench
200005	14	4015 x 1" Motor Sprocket			

N.S. – Not Shown